

IMPORTANT

PLEASE NOTE: The beam path MUST be kept clear of obstructions at all times!

Failure to comply may result in the Detector initiating a Fire or Fault signal.

NOTE: The word 'Fire' will be flashed on the System Controller when a Fire is detected.

In addition, the Detector number and Fire symbol will flash until any key is pressed.

CONTENTS

Page 1	Quick Start.
Page 2	Display & Controls - Icons.
Page 3	Display & Controls - LED Indicators.
Page 4	How to use this Guide.
Page 5/6	Viewing Menu - Main operation menu, providing 'read only' access to operating parameters.
Page 7	Enter Pass Code - To gain access to the Settings Menu.
Page 8	Settings Menu - Main programming menu, providing access to adjust operating parameters.
Page 9	Detector Settings.
Page 10	Home Position.
Page 11	LASER Targeting.
Page 12	Beam Alignment.
Page 13	Fire Threshold.
Page 14	Fire / Fault Delay.
Page 15	Fire Test.
Page 16	Software Utilities.
Page 17	Controller Settings.
Page 18	Operating Parameters.
Page 19/20	Error Codes - Explanations and Trouble Shooting.
Page 21	System Controller wiring diagram.

START

Mount and cable to all hardware.

DO NOT MOUNT REFLECTOR

Apply power to system and wait 40 seconds for Detector to power up.

Enter Pass Code
(Factory default 1234)
(See page 7)

Select current operating mode Hi or Lo (default Lo)
(See page 17)

Select Detector to be installed
(only No.1 at present)
(See page 9)

Set Distance *
(default 8-50m)
(See page 5)

Set Home Position
(See page 10)

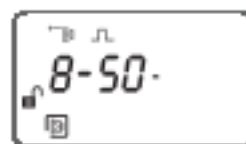
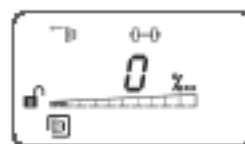
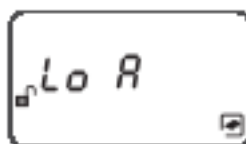
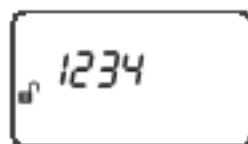

A

B

C

D

E

F

G

H

I

J

K

L



Select LASER Targeting
(See page 11)

Mount Reflector. *
(As close to LASER position as possible)



Manually Steer LASER to reflector
(See page 11)



Auto optimise
(See page 12)



Set Zero / 100%
(See page 9)



LASER RADIATION - AVOID DIRECT EYE EXPOSURE

POWER OUTPUT < 5mW

CLASS IIIa LASER

Wavelength 630 - 680 nm

* NOTE: FOR INSTALLATION OF 8-18m, PLEASE USE THE ENCLOSED SHORT RANGE MASK. PEEL OFF THE WHITE BACKING COVER TO REVEAL ADHESIVE SURFACE AND PLACE SQUARELY ON TO THE STANDARD 10cm X 10cm REFLECTOR.
(See detector install guide for more details)

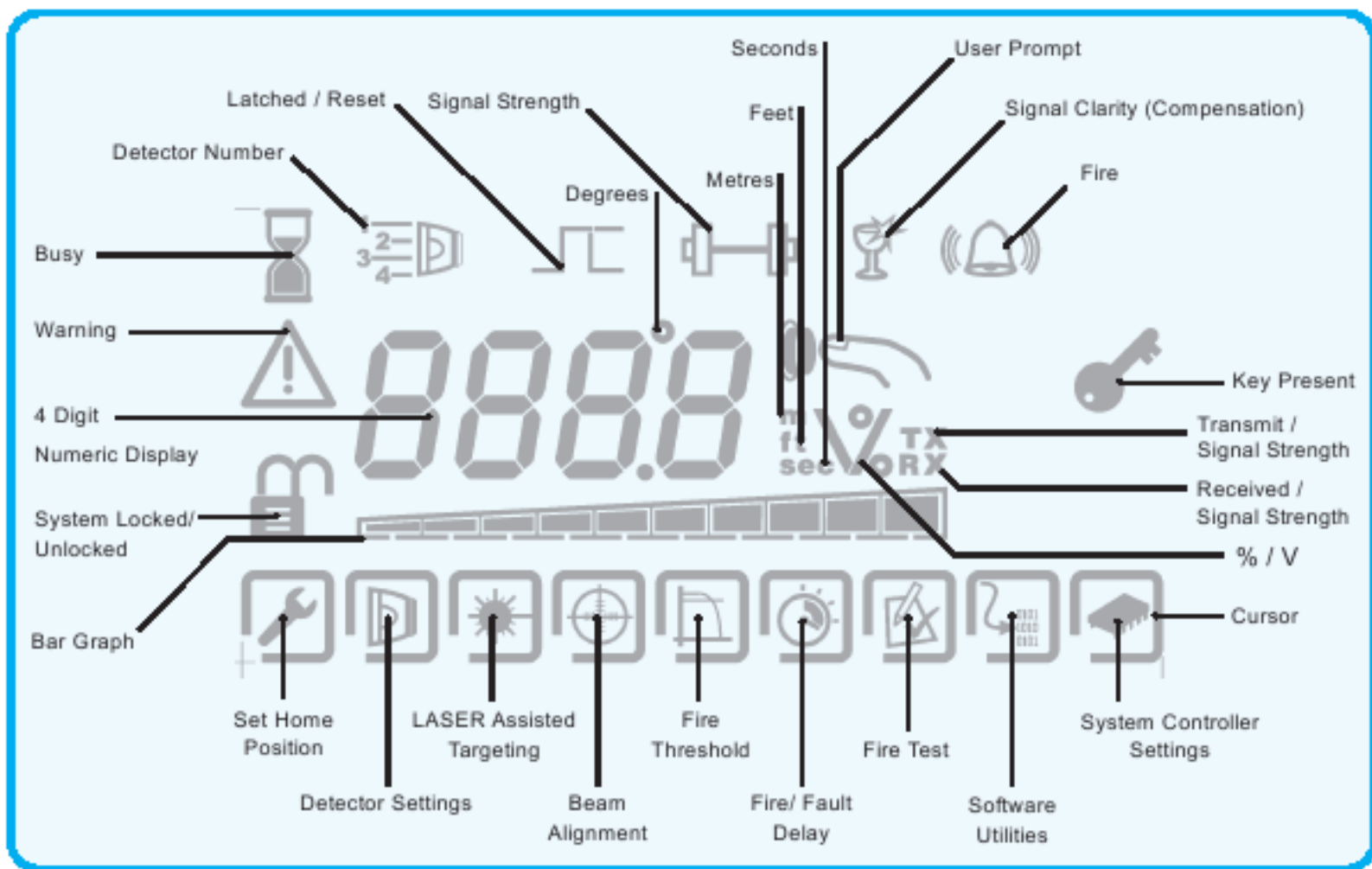
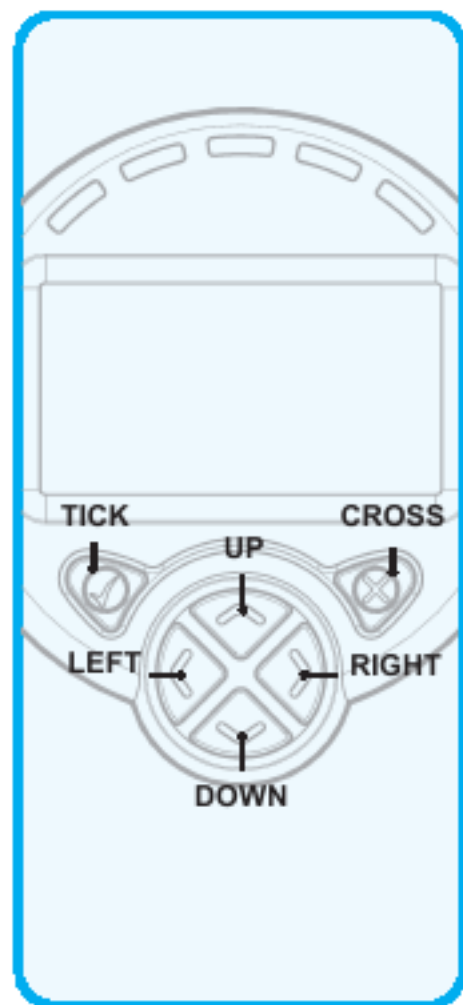

NAVIGATION



• Graphic symbols used throughout programming guide indicate Tick & Cross.

• Graphic symbols used throughout programming guide indicate Left, Right, Up & Down.

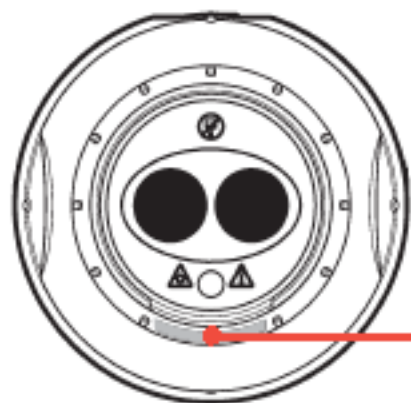

Detector - Two LED indicators:

Health - GREEN LED flashes every 10 seconds indicating the beam is in normal operation.

Status - Red / Yellow Bi-Colour LED:

- YELLOW flashes every 10 seconds indicating a Fault.
- RED flashes every 10 seconds indicating a Fire.



System Controller - Five LED indicators:

From left to right, 1, 2*, 3* & 4* are Detector Status indicators.

Status - Red / Yellow Bi-Colour LED:

- YELLOW flashes every 10 seconds indicating a Fault.
- RED flashes every 10 seconds indicating a Fire.

LED 5 is the System Controller status; a GREEN LED flashes every 10 seconds to indicate the System Controller is functioning correctly.



Default screens:

Indicated by a bold border and System Controller Bezel surround.

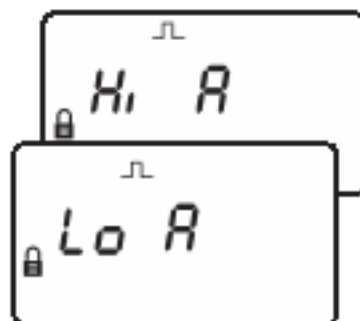

When displaying settings, one or the other would be displayed.



Screens can be navigated between and either one of them selected.



Indicates the system is 'Locked' and items may only be viewed.







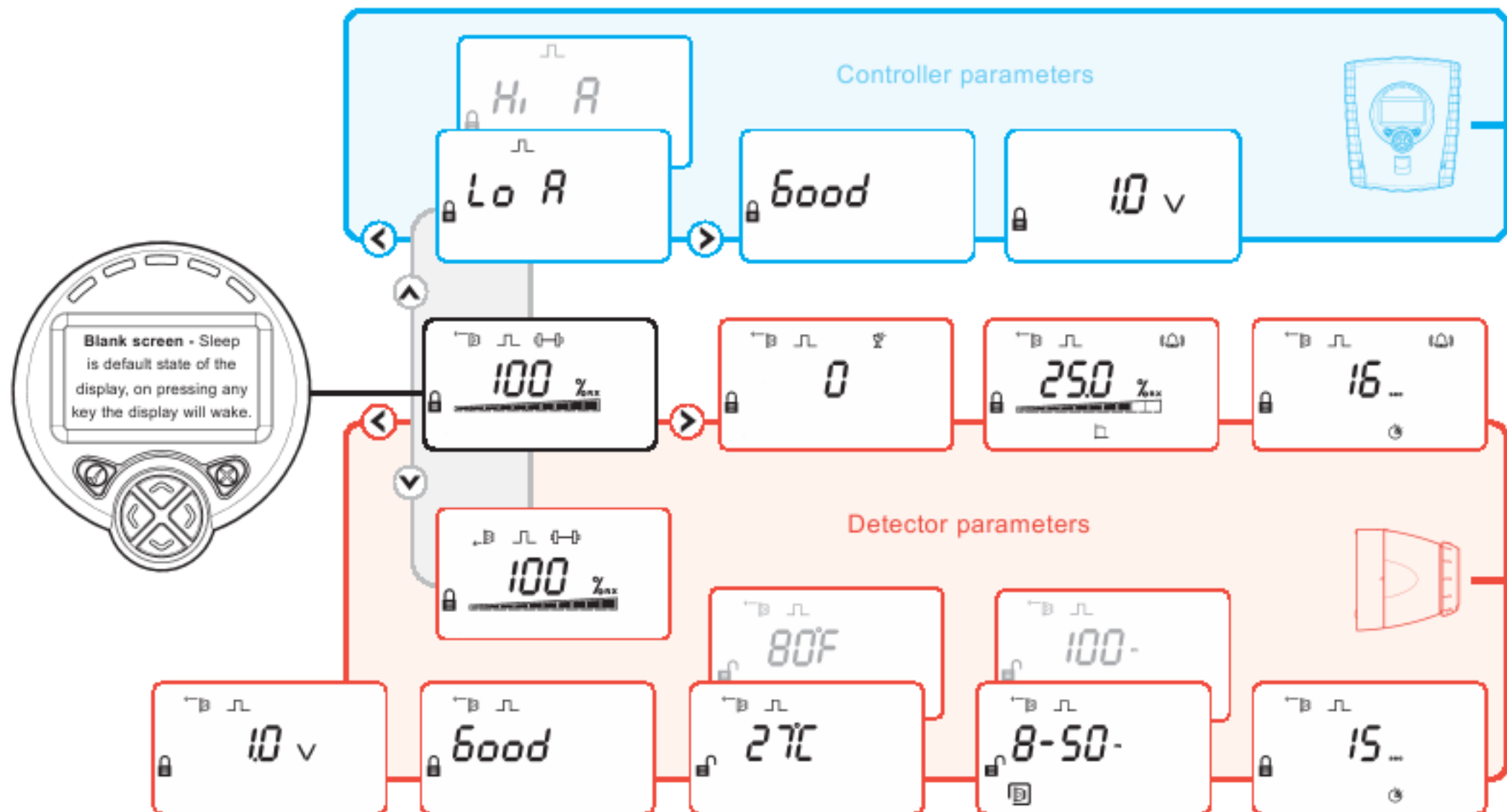

Indicates the system is 'Unlocked', so that values and settings can be altered (A valid Pass Code is required to unlock system).

NAVIGATION

- The Left & Right arrow keys move you between items on the same level.
- The Up & Down arrow keys either select items on other levels or change the value of a selected item.
- The Up, Down, Left & Right arrow keys are also used to manually steer the selected Detector.
- Selections are made by pressing the Tick key.
- The Cross key is used to exit an option without saving any changes.
- Inactivity will cause the system to time-out after 15 minutes in Engineering mode, 30 seconds in User Mode.







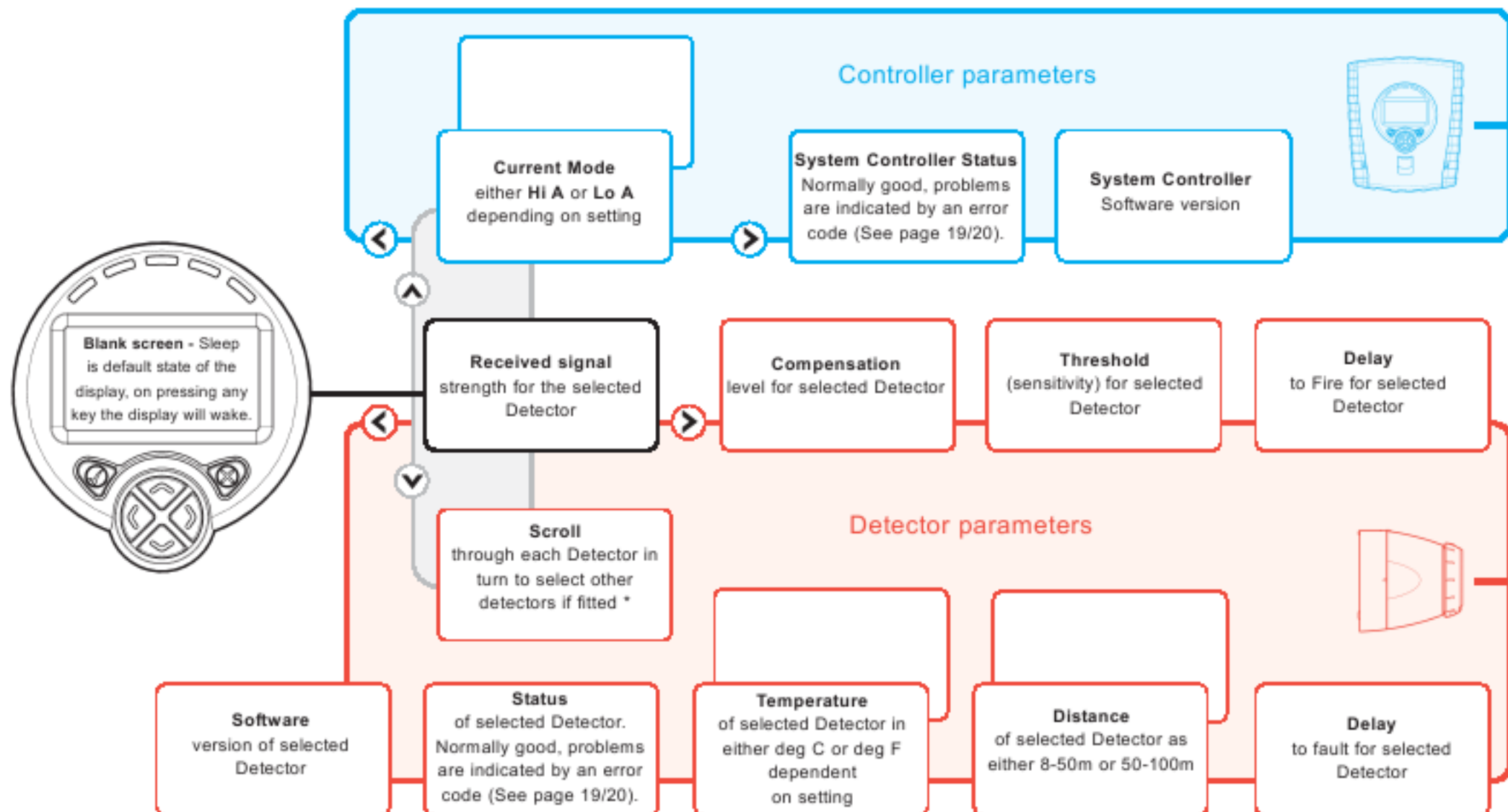

NAVIGATION

- Pressing Tick  at any point in this menu will prompt for the **Pass Code** to be entered.
- Pressing Cross  puts the system back into Sleep.
- Navigate screens using the Left  Right  Up  & Down  arrow keys.



NAVIGATION

- Pressing Tick  at any point in this menu will prompt for the **Pass Code** to be entered.
- Pressing Cross  puts the system back into Sleep.
- Navigate screens using the Left  Right  Up  & Down  arrow keys.

* ONLY AVAILABLE ON MULTI-DETECTOR UNIT

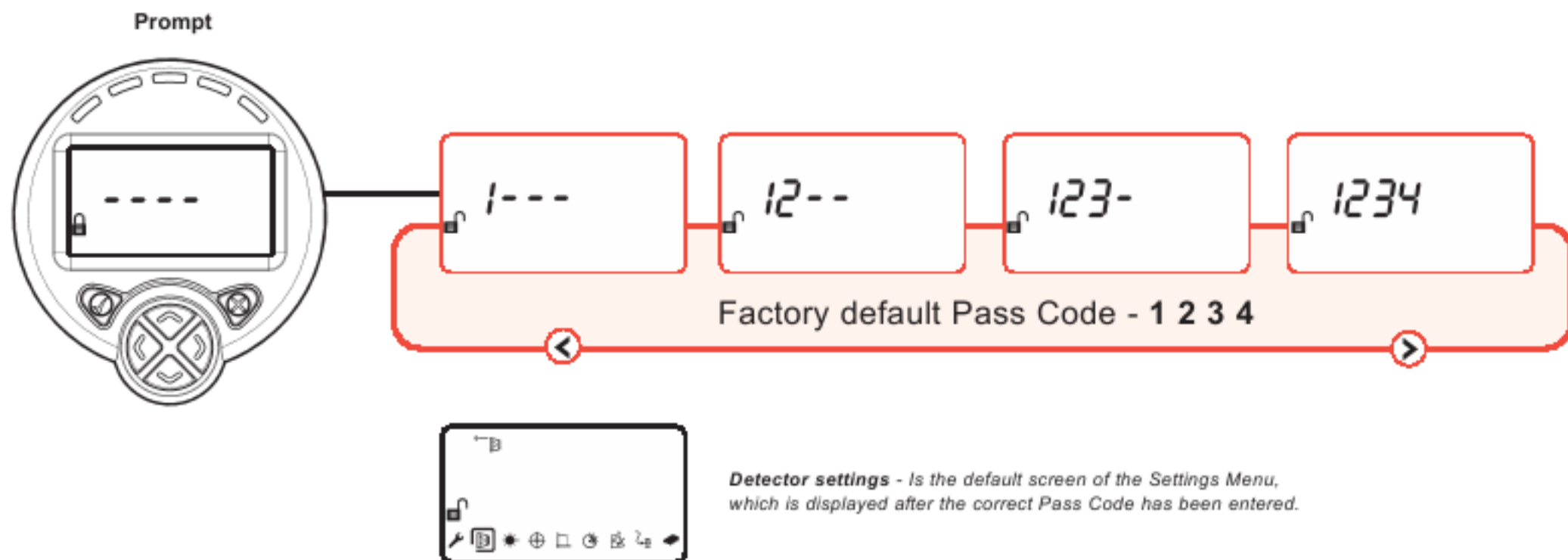



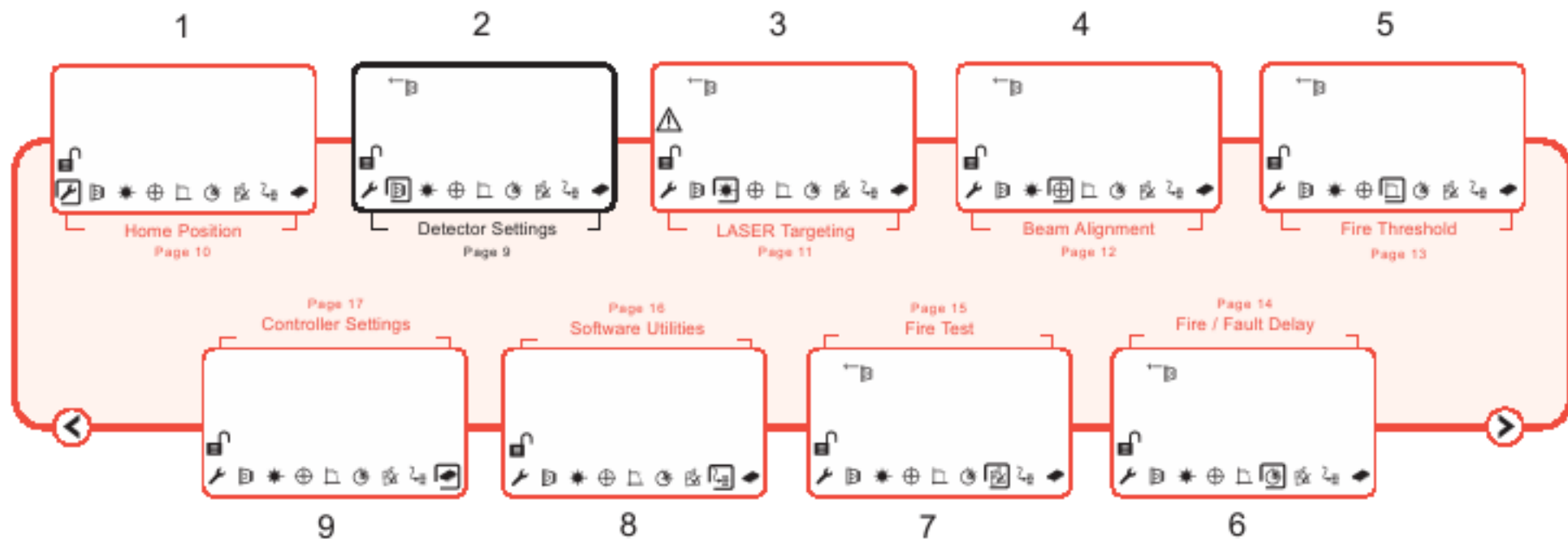

- **Prompt** - is accessed by pressing the Tick ✓ key from the User Menu.
- Flashing indicates the current cursor position.
- Each digit can be changed by using the Up ▲ & Down ▼ arrow keys.
- Use the Left ◀ & Right ▶ arrow keys to move between digits.
- When all the digits have been set correctly, press the Tick ✓ key. If the Pass Code is correct, the Settings Menu will be displayed. If the Pass Code is incorrect the display will return to the prompt. After three incorrect attempts, the system will lock access for three minutes.
- Pressing the Cross ✗ key at any time returns the display to the User Menu.
- Note: If no keys are pressed for 30 seconds the system will Lock and 'Sleep'.

NAVIGATION



NAVIGATION

- A valid **Pass Code** (See page 7) must be entered before any of these functions can be accessed.
- The menu is navigated by the use of the Left  & Right  arrow keys, which moves the cursor. Items are selected by the use of the Tick  key.
- Pressing the Cross  key exits this menu and returns the system to a 'locked' state.



Pressing the Tick key stores the change and returns to the settings menu.

Pressing the Cross key ignores any changes and returns to the settings menu.

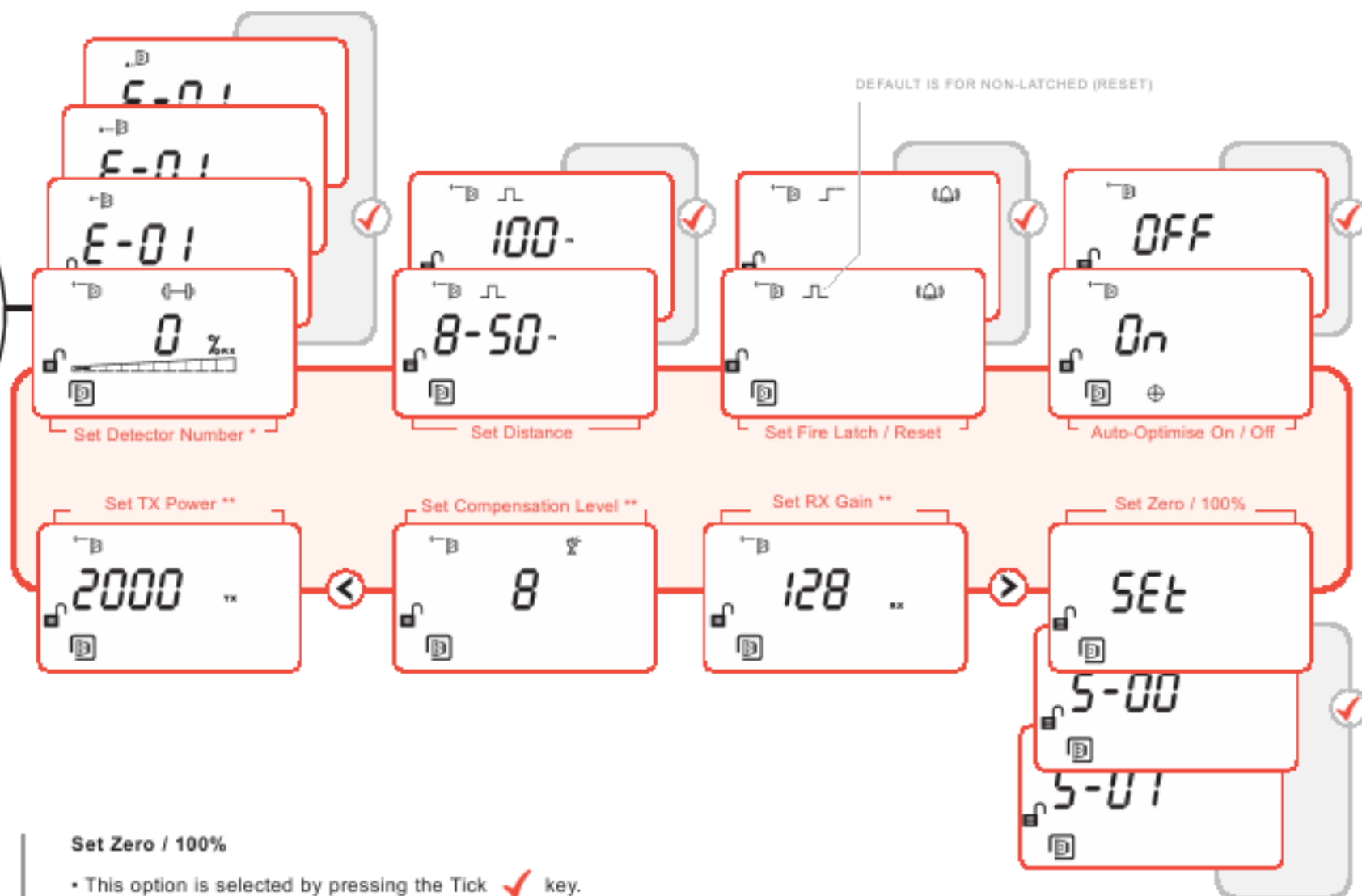



Set Zero / 100%

- This option is selected by pressing the Tick key.
- Prior to selecting this item ensure the beam is properly aligned and the reflector is uncovered.
- S-00 (Step 0) is displayed, the installer MUST cover the reflector and then press the Tick key whilst it is still covered.
- S-01 (Step 1) is displayed, the installer can now uncover the reflector and then press the Tick key.
- The system will now return to the settings menu.

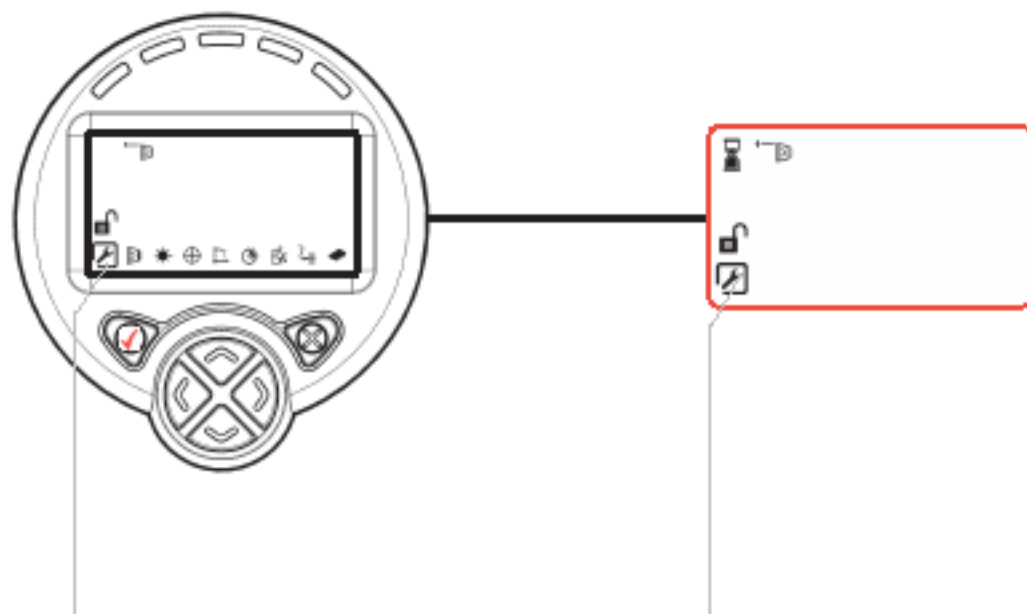
NAVIGATION



Home Position.

- Selecting this option automatically steers the motor to the Home Position.
- Pressing either the Tick  or the Cross  key, exits this function and returns to the settings menu.
- Whilst performing this function the Busy icon will flash.
- Please note this will take up to 15 minutes to complete.
- When complete it will return to the Settings Menu.

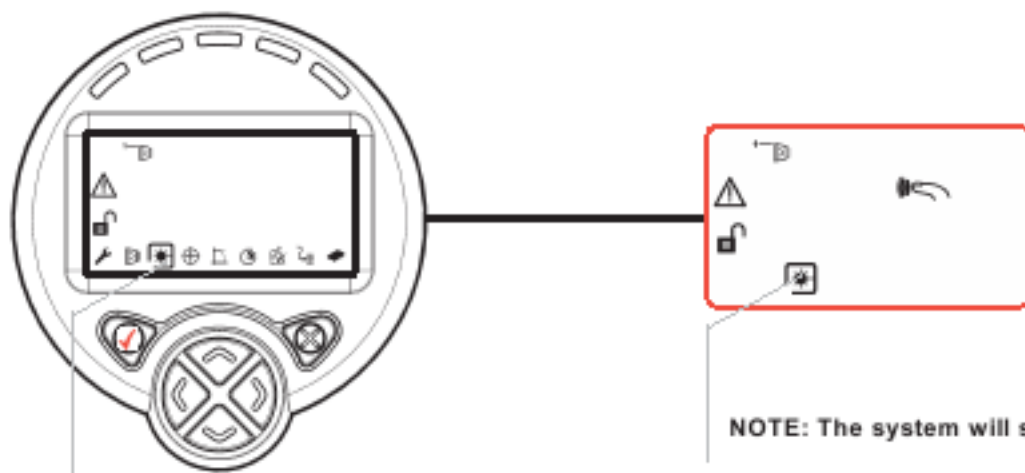

LASER:





When the cursor is placed over this option, the warning symbol will flash. This is to indicate that selecting this option will cause the LASER to come on.



LASER RADIATION - AVOID DIRECT EYE EXPOSURE
POWER OUTPUT < 5mW
CLASS IIIa LASER
Wavelength 630 - 680 nm

NOTE: The system will signal fault while in this mode

- Selecting this option turns the LASER on and the screen above will be shown.
- The motor control is enabled and the user may now steer the motor to the required position using the arrow keys.

NOTE: One press of an arrow     key results in one movement of the Detector head.

- Pressing either the Tick  or the Cross  key, causes the LASER to turn off and returns to the Settings menu.

NOTE:

The LASER should be used as an approximate alignment guide only.

The LASER and the Infrared Beam are not on the exact same axis, therefore once the Beam has been aligned the LASER may appear to be off the reflector.



If not possible to see the laser due to installation environment (eg, cannot see reflector or high ambient light) then hand-alignment must be used (see page 12). Auto-alignment must always be performed after this.



To use hand-alignment as part of beam installation:

1. Ensure detector and reflector are mounted opposite in clear line of sight.
2. Select 'Auto' alignment first and press Cross  after two seconds.
3. Select 'Hand' alignment.
4. Steer beam until the returned signal strength is above 800.
5. Perform 'Auto' alignment.



Alignment:

On selecting this option the Auto screen is displayed as shown. This can be toggled between Auto and Hand (manual) by using the Left  & Right  arrow keys.

Pressing the Tick  key selects the option currently displayed, pressing Cross  returns to the main Settings Menu.

NOTE:

User must set zero/ 100% (page 9) after either of these functions for correct operation

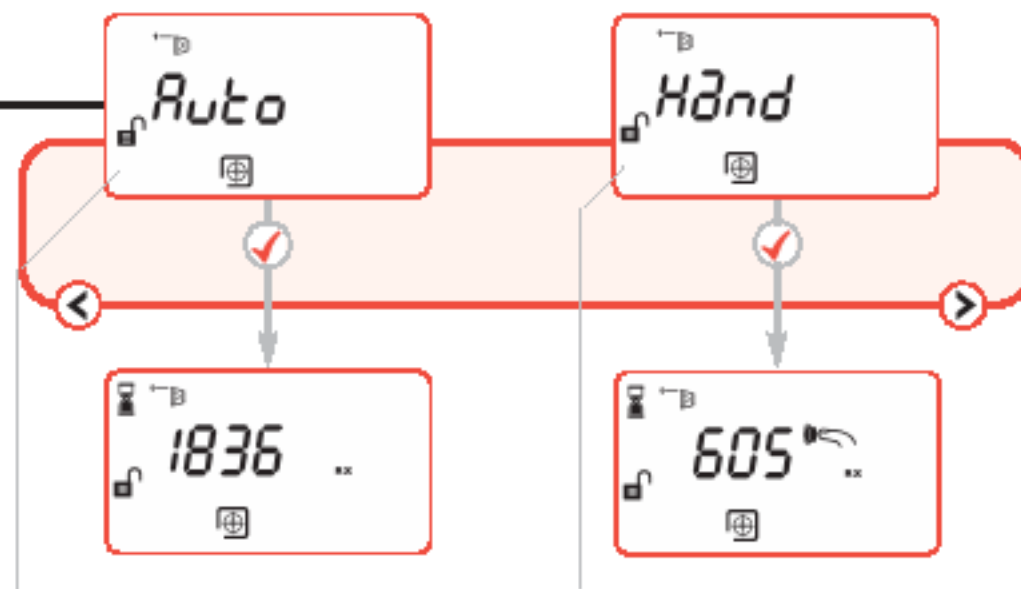





Auto:

This option uses the infrared beam to search for a maximum returned value and returns to the Settings Menu when complete.

Please note this will take up to 12 minutes to complete.

RX gain and TX power are optimised automatically.







Hand:

This option displays the current returned signal value of the infrared beam. The installer can use the; Left  Right  Up  & Down  arrow keys to steer the motor until a maximum value is achieved.

There is no auto-repeat function on any key. To move the motor in any given direction more than once, press that key multiple times.



Pressing Tick  or Cross  when finished returns to the main settings menu.





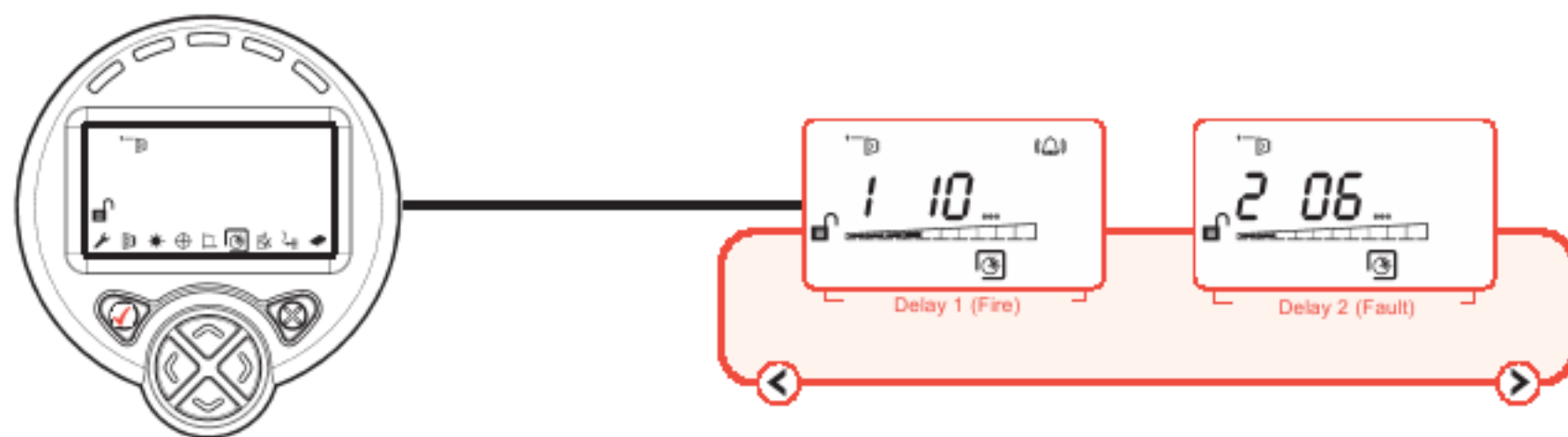

- The main default settings of 25%, 35% and 50% can be scrolled through by use of the Left  & Right  arrow keys; these can then be changed in steps of 1% by use of the Up  & Down  arrow keys.
- When the desired level has been set, the Tick  key is pressed to save the value and the system returns to the settings menu.
- Pressing the Cross  key ignores any change and returns to the Settings Menu.

NAVIGATION



On entering this option Delay 1 (Fire) is displayed; Delay 2 (Fault) is accessed by using the Left  & Right  arrow keys, which toggle between the two delays. It is not possible to set the Delay to Fire to less than the Delay to Fault.

- The value of either delay is adjusted in steps of one second by use of the Up  & Down  arrow keys.
- Pressing the Tick  key saves the current delay values and returns to the settings menu.
- Pressing the Cross  key ignores any changes and returns the the settings menu.



Fire Test:

A fire test is performed by the system overriding the set threshold (sensitivity) and setting it to 25%. The signal level is then reduced such that the received signal < 74%, forcing the system into fire. On exiting this option the signal level and threshold setting are returned to their original values.

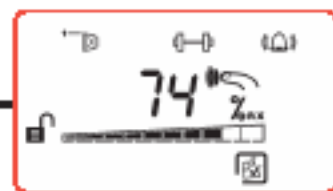

Confirm screen:

When this screen is displayed the system is waiting for the user to confirm they wish to perform the test.

Pressing the Tick  key confirms and proceeds with the test.

Pressing the Cross  key exits without performing the test with the signal and threshold unchanged.

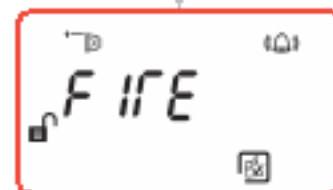

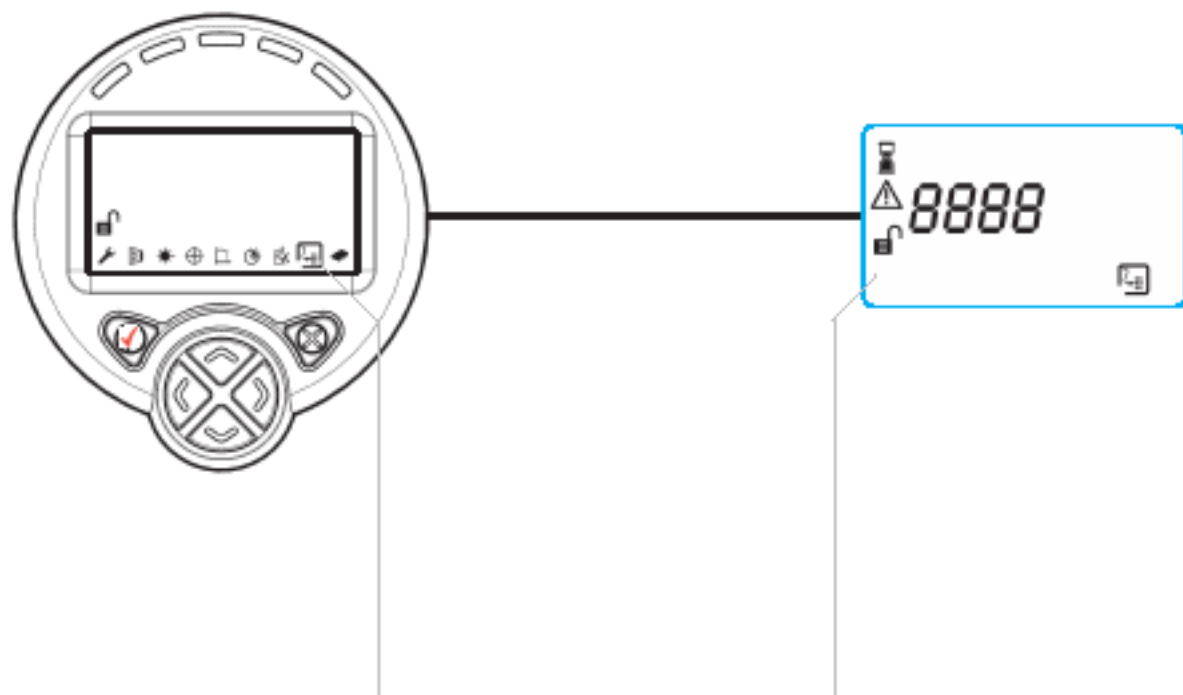

Fire screen:

The system is now in Fire and the user may press the Tick  or the Cross  key to exit and return to the settings menu.



On selecting this option the diagnostics port is enabled and communication is possible with the interface application. ***

Exit this option by pressing either the Tick  or the Cross  key and return to the settings menu.



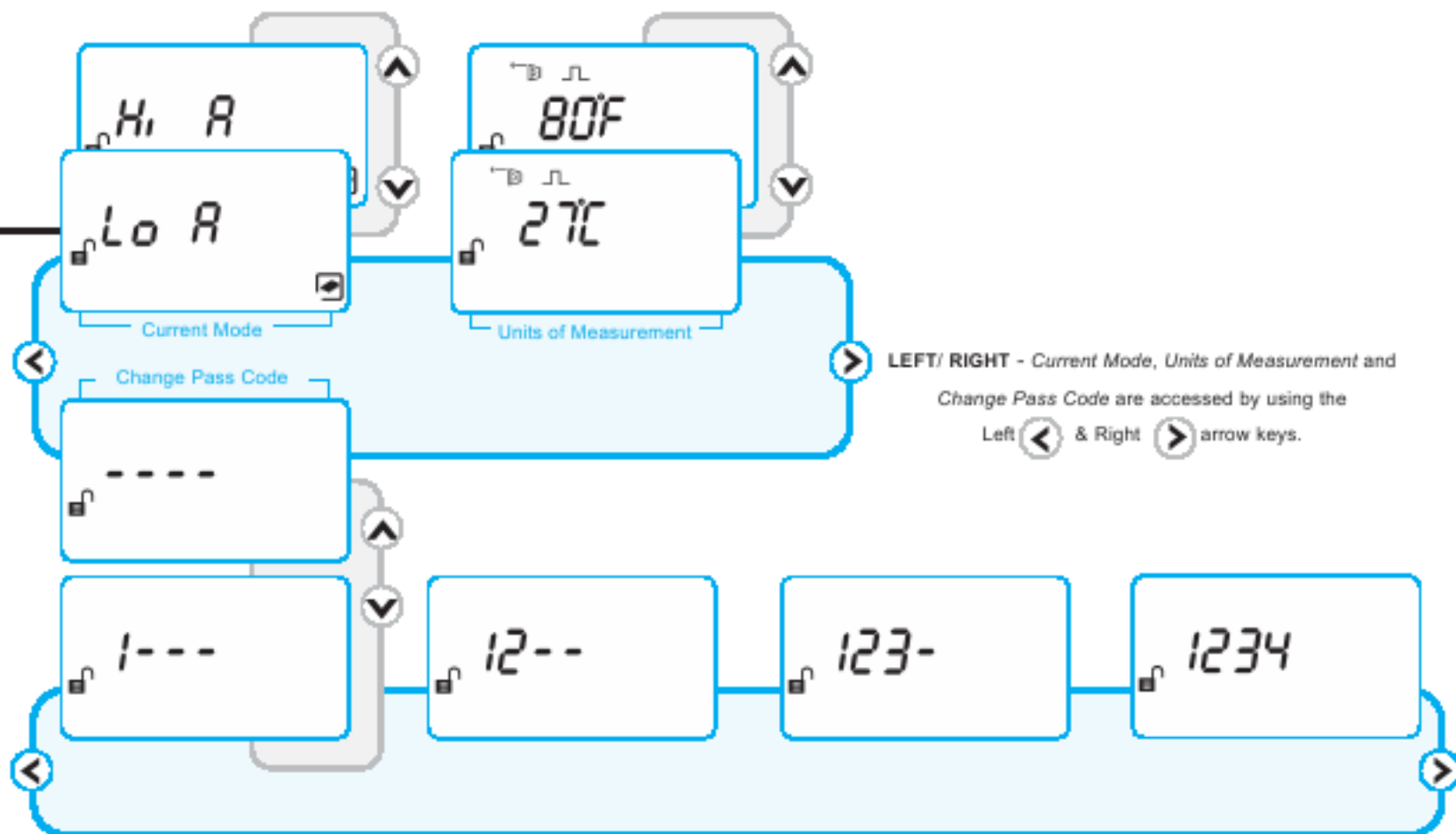

Pressing the Tick key stores the change and returns to the settings menu.

Pressing the Cross key ignores any changes and returns to the settings menu.



WARNING

Care must be taken when changing the Pass Code. If lost the unit can not be unlocked and must be returned to the manufacturer. This is not covered by the warranty.

- **Current Mode** - Sets the system into either high or low operating current mode.
- **Units of Measurement** - Changes the units of measurement.
- **Change Pass Code** - Press the Tick  key on the Pass Code screen to accesses the option to change the system Pass Code. Each digit is accessed by the Left & Right arrow keys, the value of each digit being altered by the Up & Down arrow keys.
- Pressing the Tick  key commits the new Pass Code and returns to the settings menu.
- Pressing the Cross  key ignores any change and returns to the settings menu.

Mode	Parameter	Default
Pass code	User Code required to access settings	1 2 3 4
Current Mode	Hi: the system will draw a constant maximum for configuration Lo: The system will draw a constant minimum for configuration	LO
Compensation	Range -50 to +205. Default value 0 on auto optimise This is used by the system to amplify the signal, compensating for dust build-up and building movement. At 100 auto align is invoked	0
Transmit power	Range 50 to 4095. Sets the intensity of the IR LED. The higher the value the greater the intensity. Set automatically (by auto-optimize)	
Received Gain	Range 1 to 255. Sets the received signal amplification from the IR receiver. The higher the value the greater the gain. Set automatically (by auto-optimize).	
Fire Threshold	Range 10% to 60%. Sets the amount the signal needs to fall by to signal a fire where 10% is the most sensitive. i.e. a setting of 35% means the signal needs to fall to or below 65% to be a fire	35%
Delay to Fire	Range 2s to 30s. Sets the time the system needs to be below the fire threshold before a fire signal is sent to the fire panel.	10 seconds
Delay to Fault	Range 2s to 30s. Sets the time the system needs to be below the 13% before a rapid obscuration fault is sent to fire panel. Note the signal needs to fall to <=13% within 2s	10 seconds
Distance	8m-50m or 50m-100m. Sets the beam operating length. Effects initial transmit power at start of auto optimise	8-50
Auto align	Disables or enables auto align.	ON
Latched/non-latched	Sets if the system will latch into a fire when one is detected. Faults are always non-latching.	Non-latching

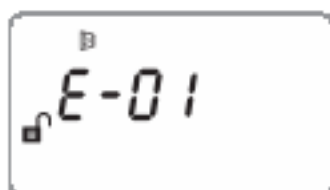

E-01 DETECTOR NOT FOUND

The System Controller can not locate a Detector at the selected number. This is also shown during power up.

Pointers:

- Wait 45 seconds for system power up
- Ensure peelable mask is removed from detector First fix
- Check wiring.

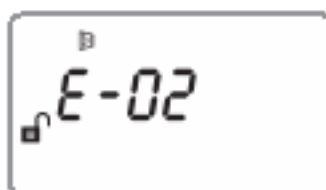

E-02 NO VALID SERIAL NUMBER

The Detector serial number is not valid, there is a potential fatal error with the Detector.

Pointers:

- Contact manufacturer.

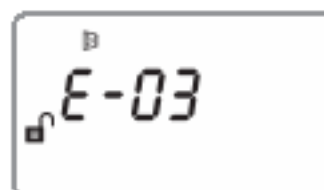

E-03 EEPROM Write

There was an error writing to the EEPROM.

Pointers:

- Power down system for 1 Minute.
- If error code seen again call manufacturer.

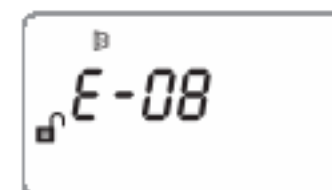

E-08

Compensation has not been set to default of zero.

Pointers:

- Re-align beam using auto-optimize.

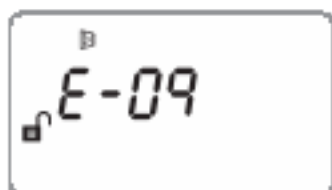

E-09

Received signal strength out of range.

Pointers:

- Ensure correct distance has been set.
- Ensure correct reflector type has been used.
- Re-align beam using auto-optimize.

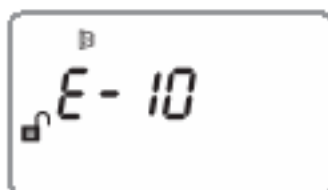

E-10 REFLECTOR NOT FOUND

The beam can not align onto the reflector, retry LASER targeting or manual alignment.

Pointers:

- Ensure correct distance has been set.
- Ensure correct reflector type has been used.
- Ensure clear line of sight to reflector.
- Re-align beam using auto-optimize.

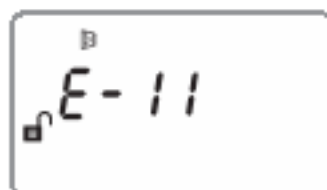

E-11 AUTO-OPTIMISE FAILED

The routine timed out whilst trying to maximise signal strength, the reflector may have been obscured.

Pointers:

- Ensure correct distance has been set.
- Ensure correct reflector type has been used.
- Ensure clear line of sight to reflector.
- Re-align beam using auto-optimize.

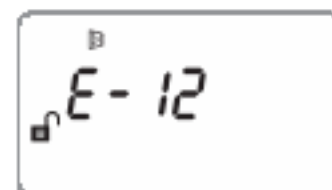

E-12 CAN'T ZERO

The reflector was not properly covered or the beam is not aligned onto the reflector.

Pointers:

- Ensure reflector was uncovered when 'set' was selected.
- Ensure reflector was covered with a non-reflecting material.

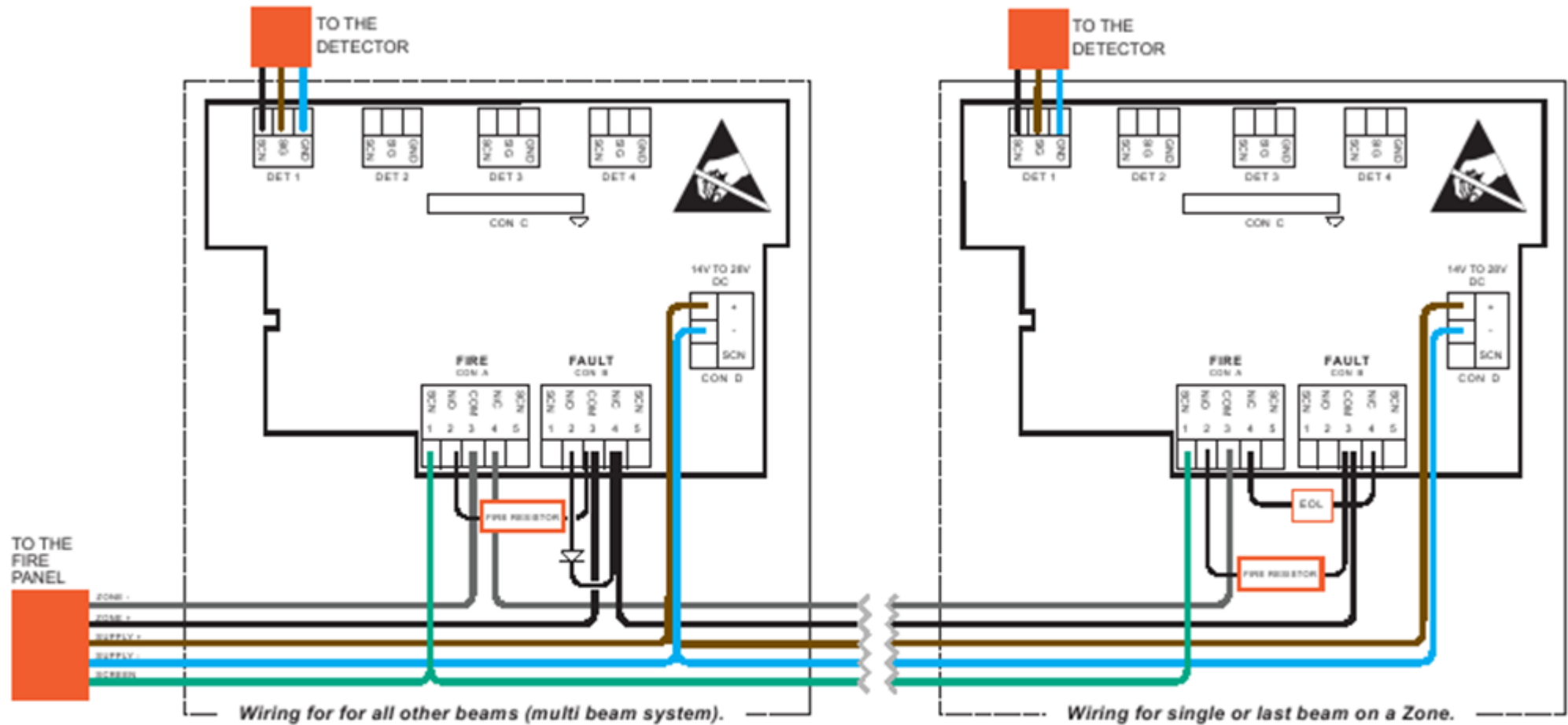

Please Note:

- The operation for Fire and Fault should always be checked for correct connection to the fire panel.
- Contact the Fire Panel manufacturer for the values of the 'Fire Resistor' and the End Of Line component (EOL).