

NOTES

HIMAX VIET NAM

THIET KE : HI-MAX VIET NAM

GIAM SAT : HI-MAX VIET NAM

Sprinkler system(P/V) - P Type

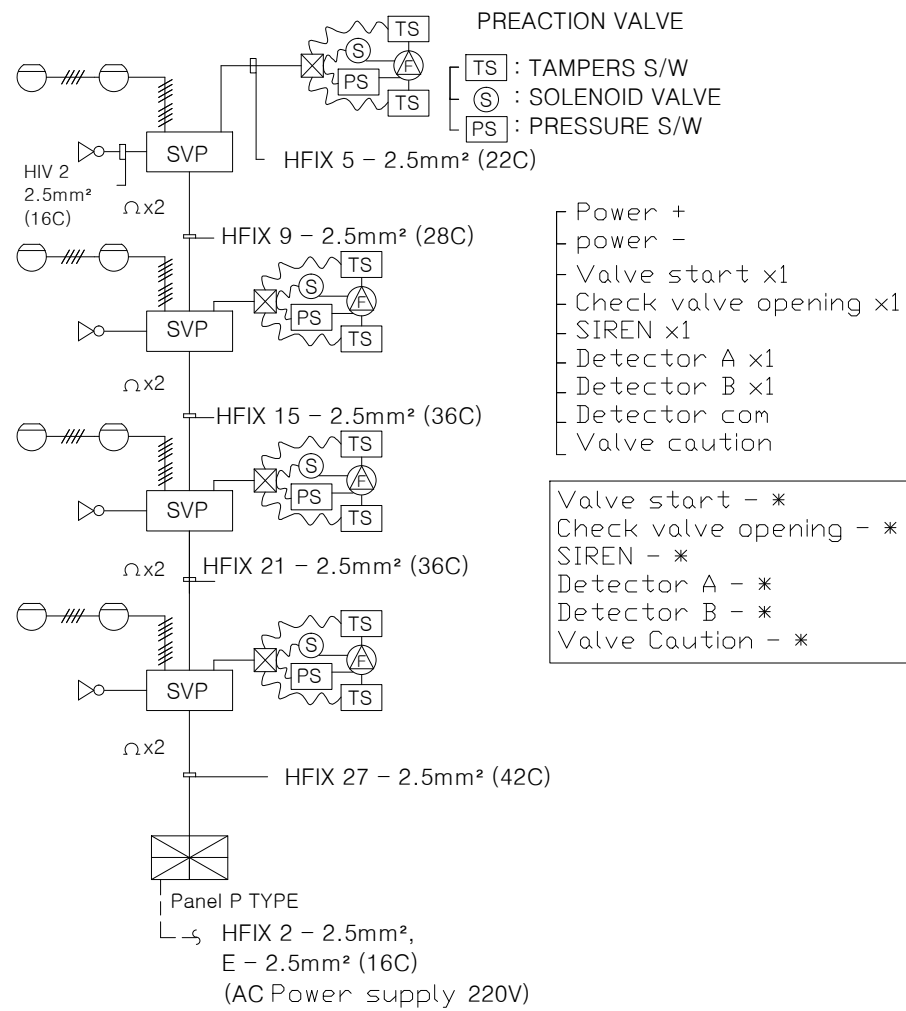

NOTE 1. * increase in addition of 1 P / V.

Sprinkler system(P/V) - R Type

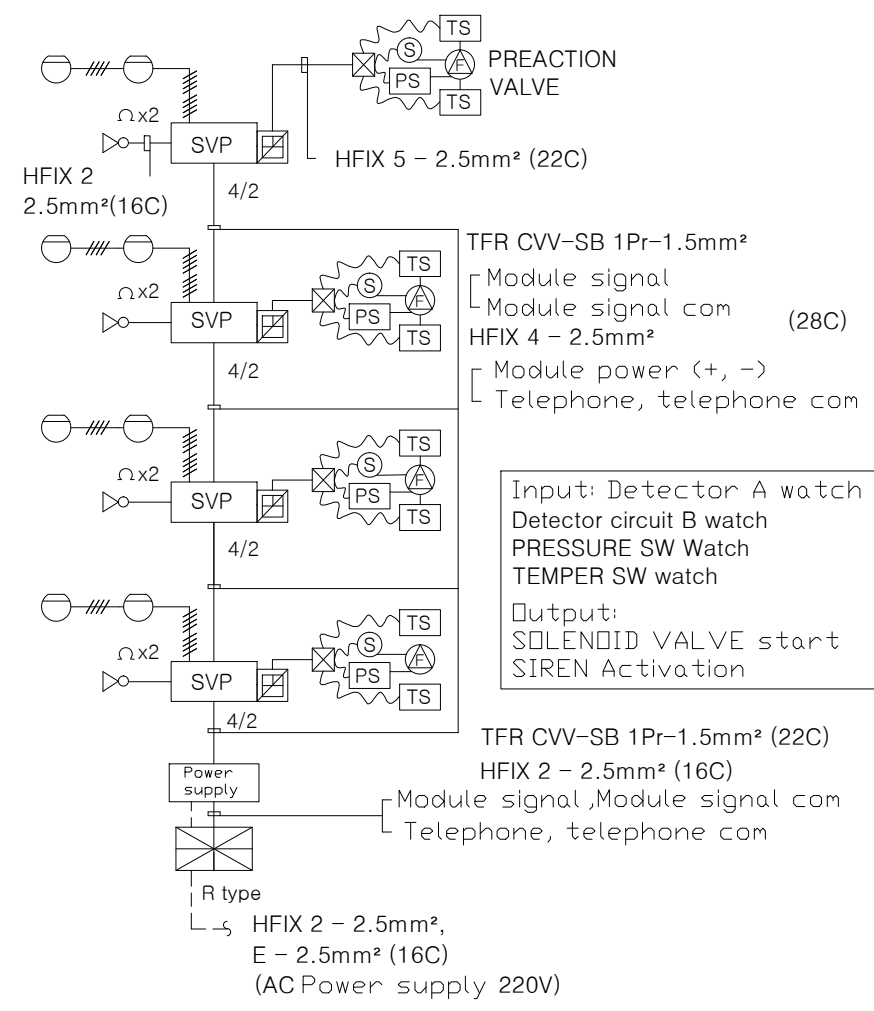

NOTE 1. Module is installed inside SVP built-in Module enclosure

FOR APPROVAL

REV.	DATE	DESCRIPTION	DRWN	DESN	CHKD	APPD	APPD

Project Name
HI-MAX VIET NAM

HI-MAX VIET NAM CO., LTD

HI-MAX VIET NAM CO., LTD
Lo B5F, KCN Hiep Phuoc, Nha Be, Tp. HCM

Title
D.W CONNECT SPRINKLER SYSTEM (P/V) P-TYPE & R-TYPE

Project No.	Drawing Number	Rev.
Part Fire Alarm System	Scale -	Microfilm No.